

TEIL - 2

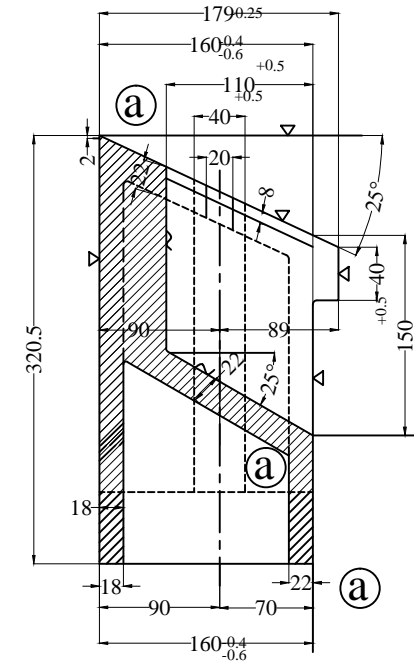

SECTION AA

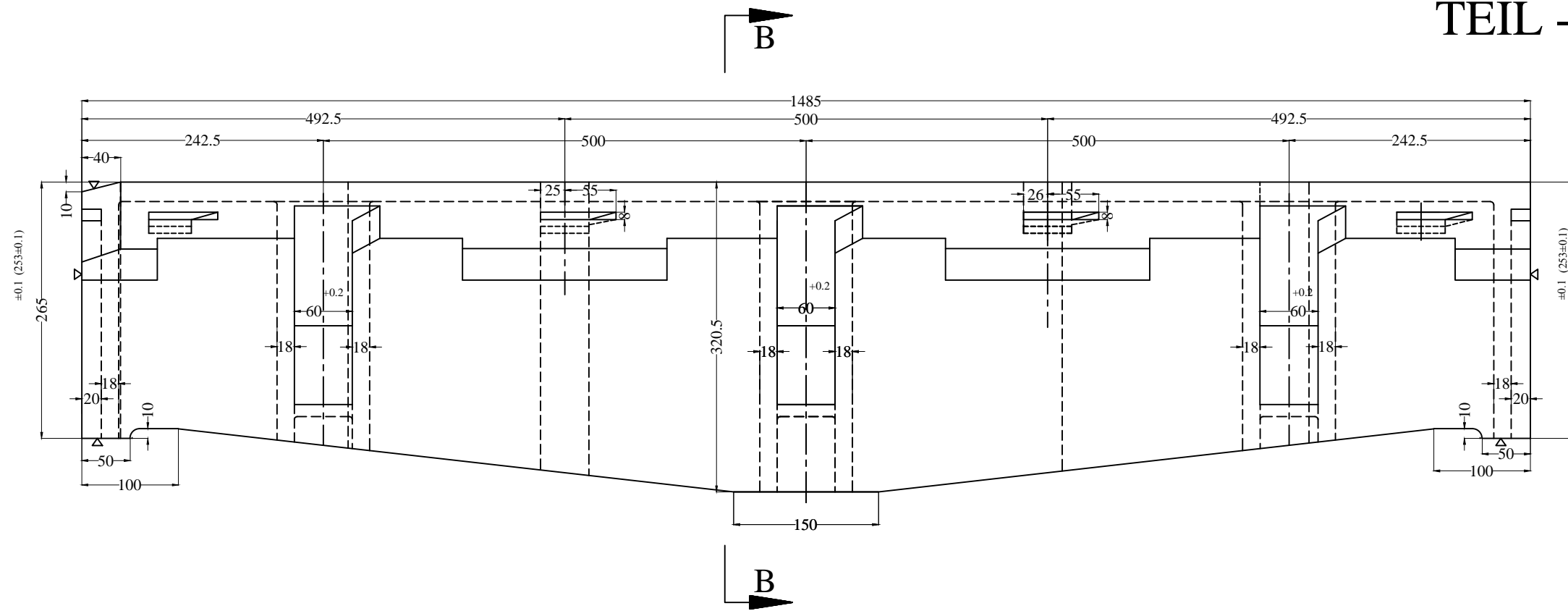
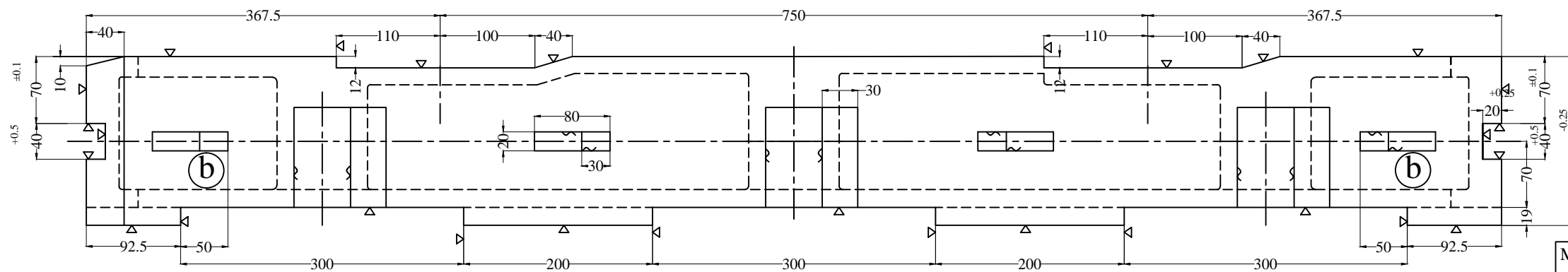

ALL DIMENSIONS ARE IN MM.

MATERIAL : GG 25 GREY CAST IRON
 MAX : WORKING TEMP 350° C
 200 - 230 BHN

IS STANDARAD
 FG 300
 IS 210
 PART SHOULD BE STRESS RELIVED

MATERIAL :	BRAKE SLIDER (EJECTOR)		
HARDNESS :	LW- 377279		
	DWG NO :	ITEM CODE NO	REV
			0
	SCALE -1:1	QTY	SHEET :