

ITALIAN PLASTICS & RUBBER PROCESSING MACHINERY INDUSTRY ~ NEWS

May 2023

PIATTAFORMA INDIA PROJECT

NEWSLETTER NO. 80



UCIMU-SISTEMI PER PRODURRE



Need Buyer Credit Finance to buy machine?

We can help you!

please write to us – italianmachinery@indiaitaly.com

EVOLUTION OF THE CUTTING CHAMBER

CMG Granulators has recently introduced a brand-new cutting chamber design for its “Evoluzione” range. The new rotor configuration allows the rotor blades to cut the plastic feedstock perpendicularly against the bed blades, obtaining the highest degree of cutting penetration and precision.

The rotor blades are mounted on the edge of the rotor holding modules and not on a holding block. Not only this feature is beneficial, as the inclination of the rotor blades is very high, but it also allows easy and quick servicing/replacement of the blades, with comfortable access from the front of the machine.

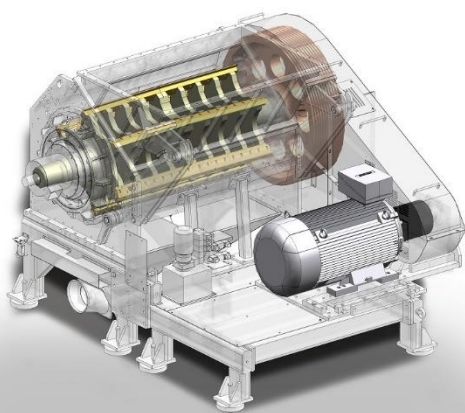

The rotation of the rotor does not produce the very detrimental “drag” effect, meaning the mass of material being ground in the cutting chamber does not rotate with the rotor producing lots of dust and fine particles, that will all become waste through the washing line. The production of fine particles is reduced to few percentage points, versus a common 15% or more from conventional granulators. The rotor is of open type design, taking only 30% of the cutting chamber volume.

The rotor/cutting chamber volume utilization ratio is 30/70, versus alternative ordinary granulators with 70/30 ratio. This feature alone allows more than double the quantity of material in the cutting chamber. The more is the material in the cutting chamber, the higher is the capacity of granulation. The new cutting chamber has the so called “tangential set up”. Such characteristic confers voraciousness and guaranteed bite, with no need of feeding aid devices, commonly utilized with conventional granulators.

www.cmg-granulators.com

The project Piattaforma India has been promoted by UCIMU – Association of Italian Machine Tools Manufacturers and AMAPLAST – Italian Plastics and Rubber Processing Machinery and Moulds Manufacturers Association. The two associations agreed on the idea that promoting a network of associations and entrepreneurs who have developed knowledge and experience on the Indian market, can be useful in favoring of new paths of development for business. The Indian companies who are interested to form JV, cooperation, technical tie up, purchase machinery etc from/with Italian companies can contact below mentioned address for any assistance:

Contact information of Piattaforma India desk:

Mr. Nilesh Joshi
Manager - Italian Machinery Desk in India



C/o The Indo Italian Chamber of Commerce and Industry
11th Floor, Tower – A, Urmi Estate, 95, Ganpatrao Kadam Marg,
Lower Parel (W), Mumbai 400013, Maharashtra
Tel: +91 22 67728186
Mob : +91 7666795385
Fax. : +91 22 67728191
Email : italianmachinery@indiaitaly.com