

ITALIAN MACHINE TOOLS, ROBOTICS & AUTOMATION INDUSTRY ~ NEWS

Sept 2024

PIATTAFORMA INDIA PROJECT

NEWSLETTER NO. 93



UCIMU-SISTEMI PER PRODURRE



Need Buyer Credit Finance to buy machine?

We can help you!

please write to us – italianmachinery@indiaitaly.com

VERTICAL HARD-BEARING BALANCING MACHINES

All rotors having a shorter axis length compared to diameter or having no shaft of their own can be conveniently balanced on balancing machines with a vertical rotation axis (e.g. grinding wheels, clutches, pulleys, flywheels, pump impellers, car wheels etc.). The balancing procedure is made possible by an adaptor or clamping tool allowing quick and easy loading/unloading of the rotor on the machine spindle. The residual unbalance depends on the centering accuracy (eccentricity) and on the centering repeatability (clearances) of the adaptor.

The errors generated by the eccentricity unbalance of the adaptor can be automatically corrected by the CEMB measuring instrument. The vertical balancing machines can be built to measure the unbalance on just one (U version) or on two planes (E version).

Model V50-100-UO

Automatic balancing machine equipped with an horizontal axis correction unit for rotors with one or two unbalance planes

The unit is assembled on a couple of slides, horizontal and vertical, moved by controlled axis directly managed by the PLC.

The measuring and material removal cycle is fully automatic.

The picture shows an optional group composed by the part clamping and a reaction device to the cutter force.

Unit features:

- Spindle taper ISO40
- Motor rating 3 kW, AC motor + inverter for variable speed from 750 to 3000 RPM
- Horizontal axis stroke 260 mm
- Vertical axis stroke 200 mm
- Option: swarf extractor

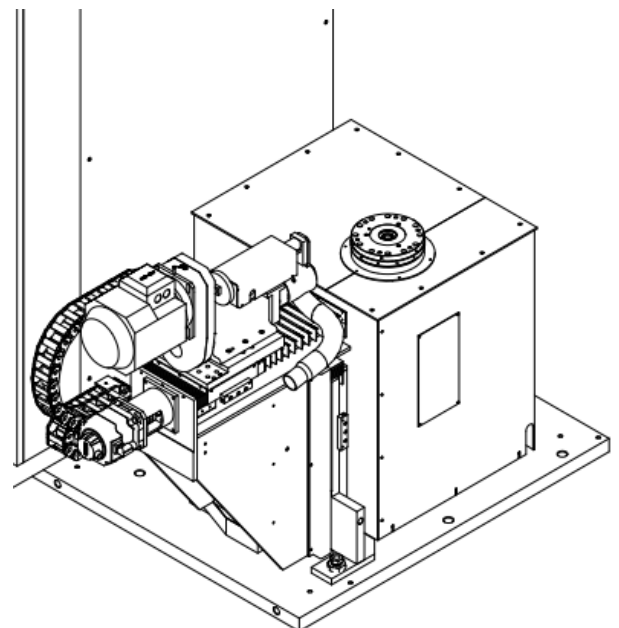

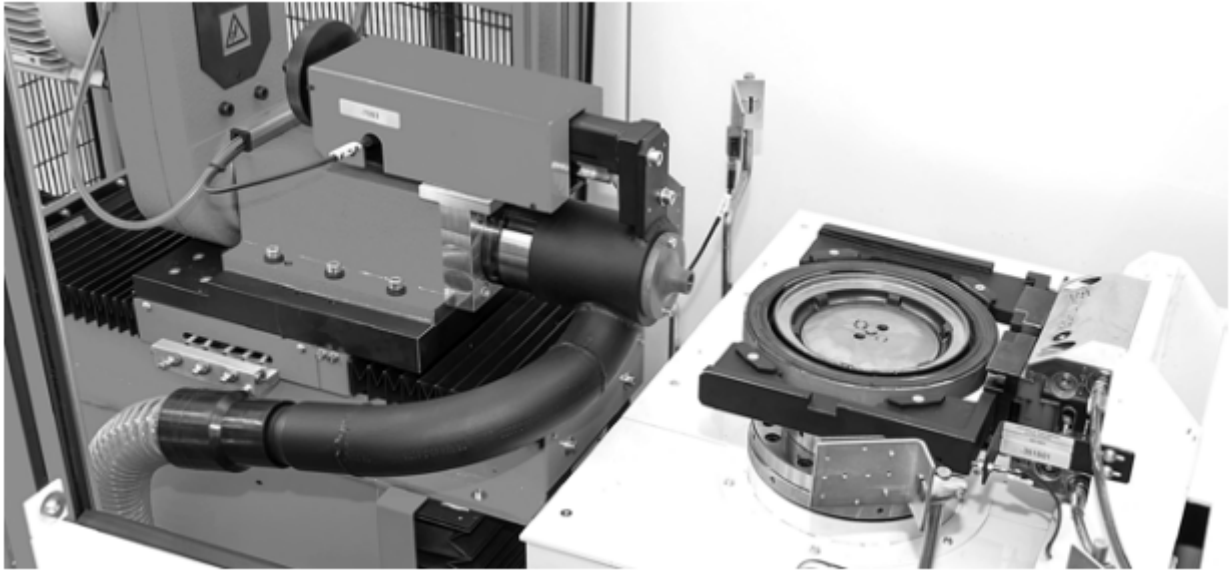

Find our products on : www.cemb.com

The project Piattaforma India has been promoted by UCIMU – Association of Italian Machine Tools Manufacturers and AMAPLAST – Italian Plastics and Rubber Processing Machinery and Moulds Manufacturers Association. The two associations agreed on the idea that promoting a network of associations and entrepreneurs who have developed knowledge and experience on the Indian market, can be useful in favoring of new paths of development for business. The Indian companies who are interested to form JV, cooperation, technical tie up, purchase machinery etc from/with Italian companies can contact below mentioned address for any assistance:

Contact information of Piattaforma India desk:

Mr. Nilesh Joshi
Business Manager - Italian Machinery in India



C/o The Indo Italian Chamber of Commerce and Industry
11th Floor, Tower - A, Urmi Estate 95, Ganpatrao Kadam Marg,
Lower Parel (W), Mumbai 400013, Maharashtra

P: +91 22 67728186

Mob : +91 7666795385

Fax. : +91 22 67728191

Email : italianmachinery@indiaitaly.com